



American Opto Plus LED Corp.

L950B-LBC-TR

5.0 x 5.0 x 1.8 mm Blue SMD LED

PACKAGE OUTLINES

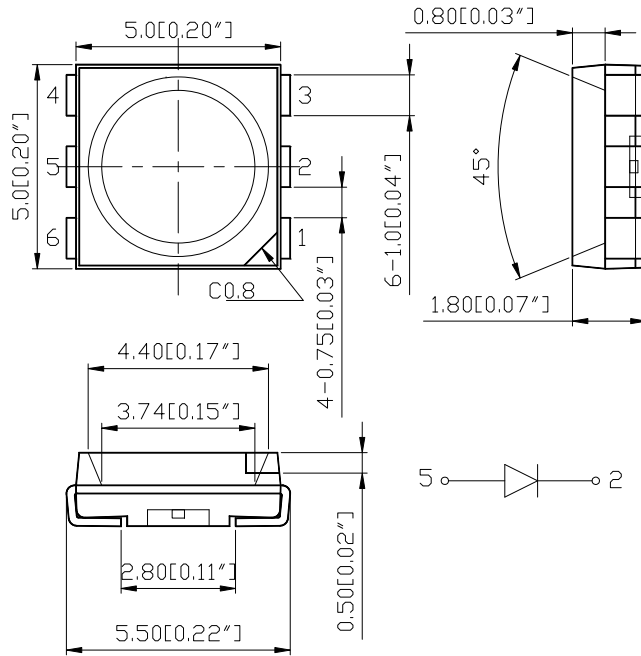

RECOMMEND PAD LAYOUT

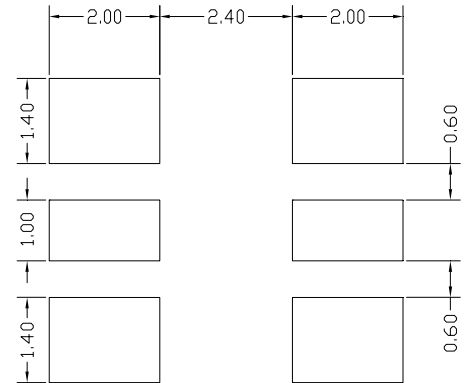

ITEM	MATERIALS
Resin	Silicon
Lens color	Water transparent
Dice	InGaN
Emitted color	Blue

NOTES:

- All dimensions are in millimeters (inches);
- Tolerances are $\pm 0.1\text{mm}$ (0.004inch) unless otherwise noted.



American Opto Plus LED Corp.

L950B-LBC-TR

5.0 x 5.0 x 1.8 mm Blue SMD LED

ABSOLUTE MAXIMUM RATINGS

(Ta=25°C)

Parameter	Symbol	Value	Unit
Forward current	I _f	30	mA
Reverse voltage	V _r	5	V
Power dissipation	P _d	111	mW
Operating temperature range	T _{op}	-40~+85	°C
Storage temperature range	T _{stg}	-40~+85	°C
Peak pulsing current (1/8 duty f= 1kHz)	I _{fp}	125	mA

OPTICAL-ELECTRICAL CHARACTERISTICS

(Ta=25°C)

Parameter	Symbol	Test Condition	Min	Typ	Max	Unit
Wavelength at peak emission	λ peak	I _F = 20mA	--	465	--	nm
Spectral half bandwidth	Δλ	I _F = 20mA	--	25	--	nm
Dominant wavelength	λ dom	I _F = 20mA	465	470	475	nm
Forward Voltage	V _f	I _F = 20mA	2.8	3.3	3.7	V
Luminous intensity	I _v	I _F = 20mA	100	190	320	mcd
Viewing angle at 50% I _v	2θ ½	I _F = 10mA	--	120	--	Deg
Reverse current	I _r	V _r =5V	--	10	--	μA

*Note: Luminous intensity tolerance is ±10%.



American Opto Plus LED Corp.

L950B-LBC-TR

5.0 x 5.0 x 1.8 mm Blue SMD LED

OPTICAL CHARACTERISTIC CURVES

Relative Intensity vs. Wavelength

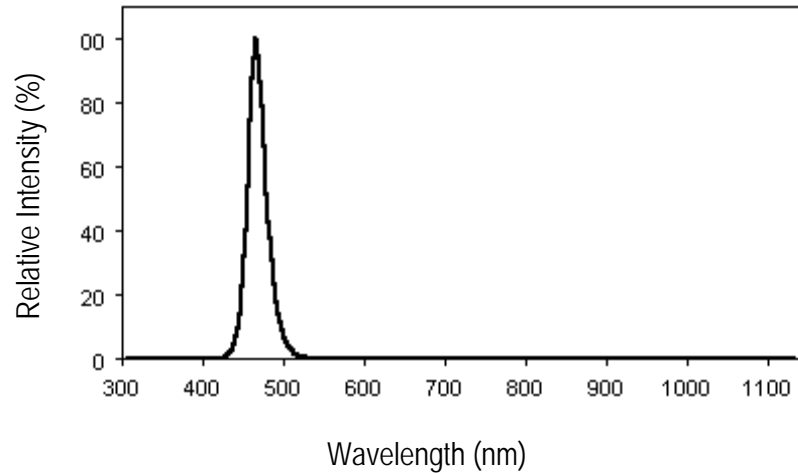

Forward Current vs. Forward Voltage

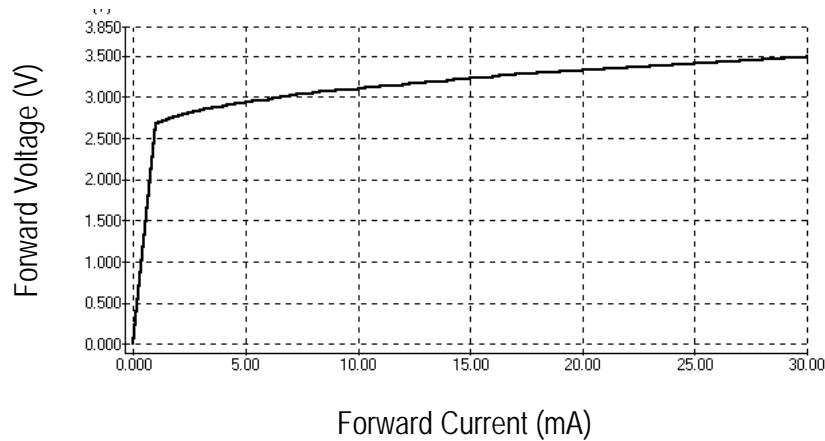

Directive Characteristics

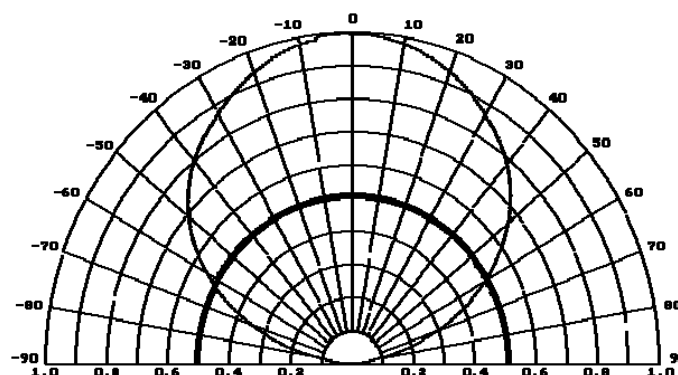



American Opto Plus LED Corp.

L950B-LBC-TR

5.0 x 5.0 x 1.8 mm Blue SMD LED

REFLOW PROFILE

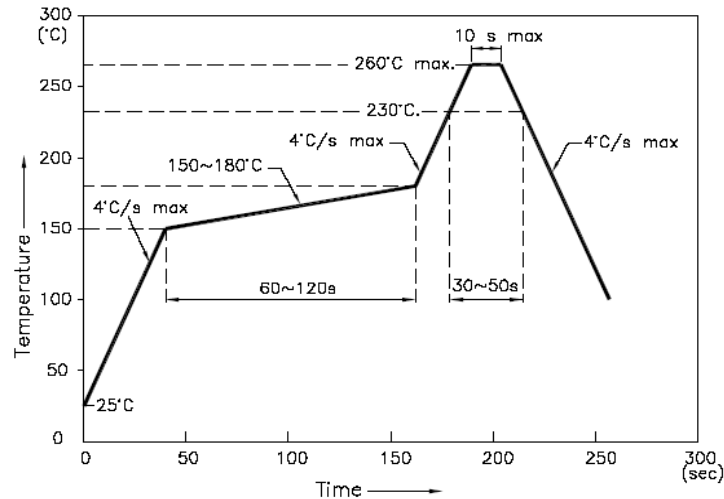

NOTES:

1. We recommend the reflow temperature 245°C (±5°C). The maximum soldering temperature should be limited to 260°C.
 2. Do not cause stress to the epoxy resin while it is exposed to high temperature.
 3. Number of reflow process shall be 2 times or less.
- Soldering iron
Basic spec is ≤ 5sec when 260°C. If temperature is higher, time should be shorter (+10°C → -1sec). Power dissipation of iron should be smaller than 20W, and temperatures should be controllable. Surface temperature of the device should be under 230°C.

Rework

1. Customer must finish rework within 5 sec under 260°C.
2. The head of iron cannot touch copper foil
3. Twin-head type is preferred.

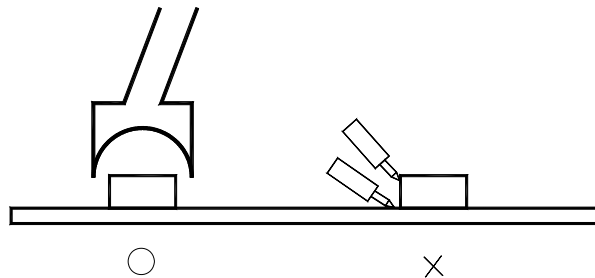

- **Avoid rubbing or scraping the resin by any object, during high temperature, for example reflow, solder etc.**



American Opto Plus LED Corp.

L950B-LBC-TR

5.0 x 5.0 x 1.8 mm Blue SMD LED

TEST CIRCUIT AND HANDLING PRECAUTIONS

- **Test circuit**

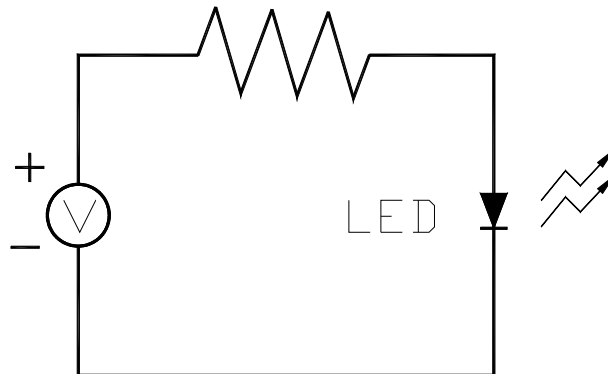

- **Handling precautions**

1. Over-current-proof
Customer must apply resistors for protection; otherwise slight voltage will cause big current change (Burn out will happen).
2. Shelf life in sealed bag: 12 month at $< 5^{\circ}\text{C} \sim 30^{\circ}\text{C}$ and $< 60\% \text{ R.H.}$
3. After the package is opened:
 - 3.1 It is recommended to baking before the first use:
Baking Condition:
 - a. $60 \pm 3^{\circ}\text{C} \times (36 \sim 48\text{hrs})$ and $< 5\% \text{RH}$, taped reel type;
 - b. $110 \pm 3^{\circ}\text{C} \times (8 \sim 16\text{hrs})$, bulk type.
 - 3.2 The products should be used within a week or they should be stored at $\leq 20 \text{ R.H.}$
with zip-lock sealed:
 - a. It is recommended to baking before soldering when the pack is unsealed after 72hrs ;
 - b. Baking condition as 3.1 baking condition.



American Opto Plus LED Corp.

L950B-LBC-TR

5.0 x 5.0 x 1.8 mm Blue SMD LED

Test items and results of reliability

Type	Test Item	Test Conditions	Note	Number of Damaged
Environmental Sequence	Temperature Cycle	-20°C 30min ↑↓ 80°C 30min	100 cycle	0/22
	Thermal Shock	-20°C 15min ↑↓ 80°C 15min	100 cycle	0/22
	High Humidity Heat Cycle	30°C ↔ 65°C 90%RH 24hrs/1cycle	10 cycle	0/22
	High Temperature Storage	T _a =80°C	1000 hrs	0/22
	Humidity Heat Storage	T _a =60°C RH=90%	1000 hrs	0/22
	Low Temperature Storage	T _a =-30°C	1000 hrs	0/22
Operation Sequence	Life Test	T _a =25°C I _F =20mA	1000 hrs	0/22
	High Humidity Heat Life Test	60°C RH=90% I _F =10mA	500 hrs	0/22
	Low Temperature Life Test	T _a =-20°C I _F =20mA	1000 hrs	0/22



American Opto Plus LED Corp.

L950B-LBC-TR

5.0 x 5.0 x 1.8 mm Blue SMD LED

PACKAGING SPECIFICATION

- Feeding Direction

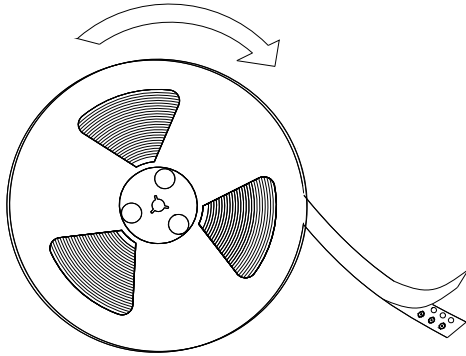

- Dimensions of Reel (Unit: mm)

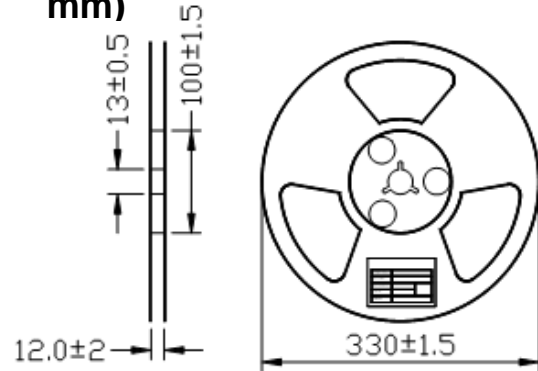

- Dimensions of Tape (Unit: mm)

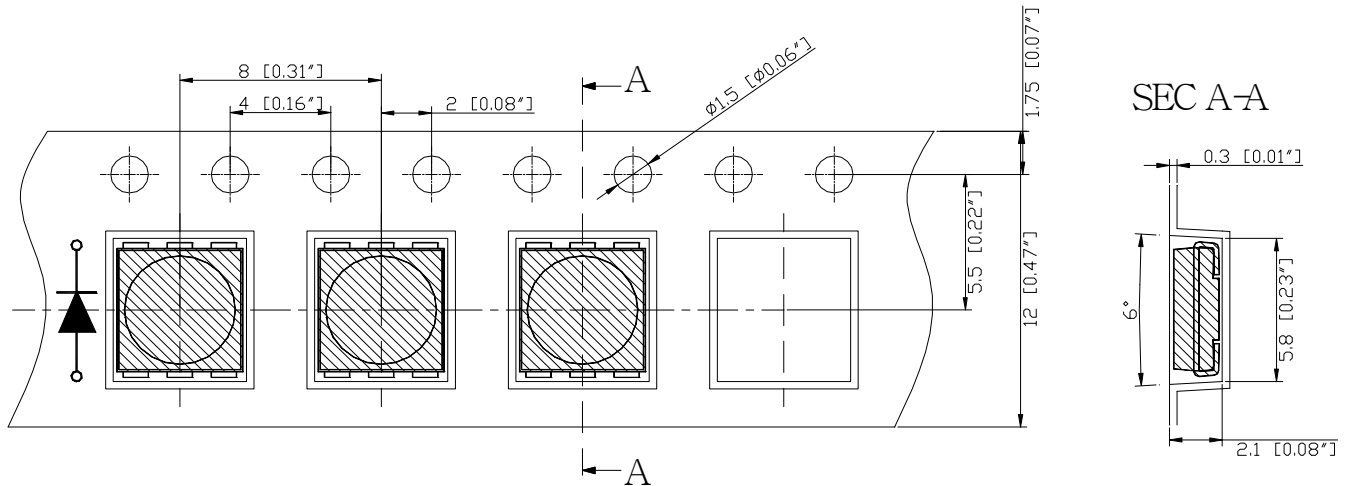



American Opto Plus LED Corp.

L950B-LBC-TR

5.0 x 5.0 x 1.8 mm Blue SMD LED

• Arrangement of Tape

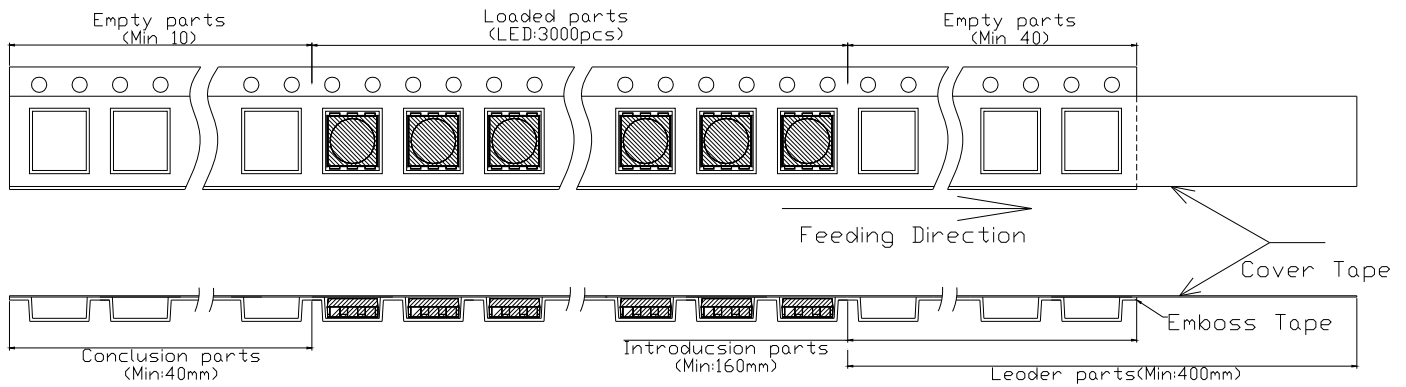

Notes:

1. Empty component pockets are sealed with top cover tape;
2. The maximum number of missing lamps is two;
3. The cathode is oriented towards the tape sprocket hole.
4. 3,000pcs/Reel



American Opto Plus LED Corp.

L950B-LBC-TR

5.0 x 5.0 x 1.8 mm Blue SMD LED

Forward Voltage Rank Combination ($I_F=20\text{mA}$)

Rank Code	Min.	Max.	Unit
f	2.8	3.1	V
g	3.1	3.4	
h	3.4	3.7	

Luminous Intensity Rank Combination ($I_F=20\text{mA}$)

Rank Code	Min.	Max.	Unit
J	100	125	mcd
K	125	160	
L	160	200	
M	200	250	
N	250	320	

Dominant wavelength Rank Combination ($I_F=20\text{mA}$)

Rank Code	Min	Max	Unit
G	465	467.5	nm
H	467.5	470	
I	470	472.5	
J	472.5	475	

Group Name on Label (Example DATA: gLH 20)

DATA: gLH 20	Vf(V)	Iv (mcd)	λ_d (nm)	Test Condition
g→L→H→20	3.1~3.4	160~200	467.5~470	$I_F=20\text{mA}$

NOTE:

1. The tolerance of luminous intensity (Iv) is $\pm 15\%$.
2. The tolerance of dominant wavelength is $\pm 1\text{nm}$.
3. This specification is preliminary.