



American Opto Plus LED Corp.

L950L-LENPGQB

5.4 x 5.0 x 1.6 mm RGB SMD LED

PACKAGE SPECIFICATIONS

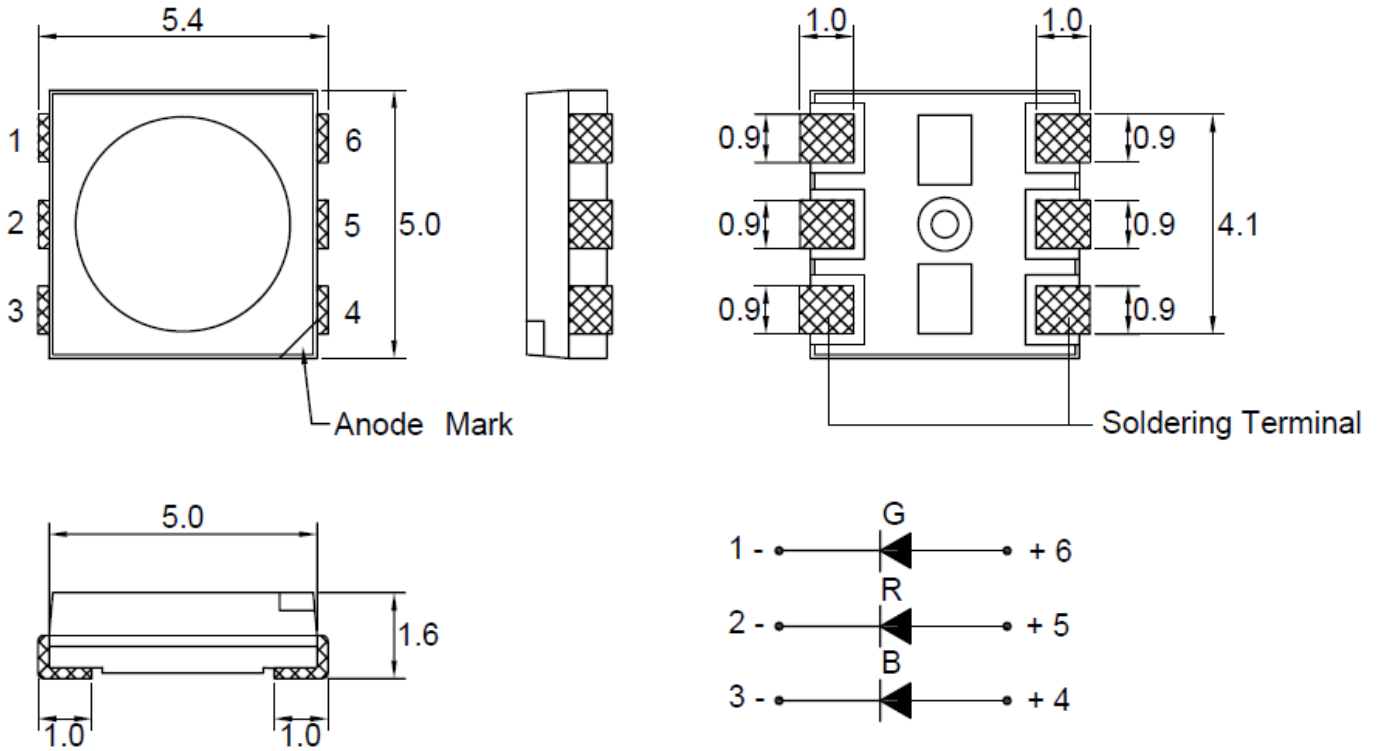

RECOMMENDED SOLDER PATTERN

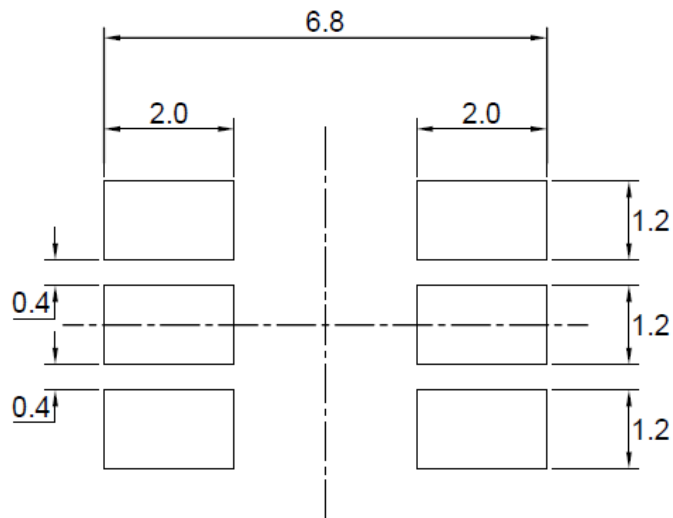

Notes:

1. All dimensions in mm.
2. Tolerance is ± 0.2 mm unless otherwise noted.



American Opto Plus LED Corp.

L950L-LENPGQB

5.4 x 5.0 x 1.6 mm RBG SMD LED

Part No.	Emission Color	Material	Lens
L950L-LENPGQB	Red	AlGaInP	Water Clear
	Blue	InGaN	
	Green	InGaN	



American Opto Plus LED Corp.

L950L-LENPGQB

5.4 x 5.0 x 1.6 mm RBG SMD LED

ABSOLUTE MAXIMUM RATINGS

(Ta=25°C)

Parameter	Symbol	Ratings			Unit
		R	PG	B	
DC Forward Current	I _F	50	30	30	mA
Peak Pulsed Current Duty 1/10@10KHz	I _{FP}	90	100	100	mA
Power Dissipation	P _D	130	108	108	mW
Reverse Current @ 5V	I _R	10	50	50	μA
Electrostatic Discharge	ESD	2000	500	500	V
Operating temperature range	T _{OPR}	-20~+80			°C
Storage temperature range	T _{STG}	-30~+100			°C

OPTICAL-ELECTRICAL CHARACTERISTICS

(Ta=25°C)

Parameter	Symbol	Condition	Min	Typ	Max	Unit	
Luminous Intensity	I _v	I _F =20mA	R	500	800	--	mcd
			PG	800	1250		
			B	125	320		
Dominant Wavelength	λ _D		R	--	624	--	nm
			PG	--	525		
			B	--	470		
Spectral Line Half-Width	Δλ	R	--	20	--	nm	
		PG	--	36			
		B	--	30			
Forward Voltage	V _F	R	1.7	--	2.6	V	
		PG	2.8	--	3.6		
		B	2.8	--	3.6		
Viewing Angle	2θ _{1/2}	All	--	120	--	deg	

Notes:

1. Luminous intensity tolerance: ±15%
2. Forward voltage tolerance: ±0.1V



American Opto Plus LED Corp.

L950L-LENPGQB

5.4 x 5.0 x 1.6 mm RBG SMD LED

LUMINOUS INTENSITY CLASSIFICATION

BIN CODE		Iv(mcd) at 20mA	
		Min.	Max.
RED	U	500	800
	V-1	800	1000
	V-2	1000	1250

BIN CODE		Iv(mcd) at 20mA	
		Min.	Max.
GREEN	V-1	800	1000
	V-2	1000	1250
	W-1	1250	1600

BIN CODE		Iv(mcd) at 20mA	
		Min.	Max.
BLUE	R	125	200
	S	200	320
	T	320	500



American Opto Plus LED Corp.

L950L-LENPGQB

5.4 x 5.0 x 1.6 mm RBG SMD LED

DOMINANT WAVELENGTH CLASSIFICATION

BIN CODE		λ_D (nm) at 20mA	
		Min.	Max.
RED	27	618	621
	28	621	624
	29	624	627
	30	627	630

BIN CODE		λ_D (nm) at 20mA	
		Min.	Max.
GREEN	1O	519	522
	1P	522	525
	1Q	525	528
	1R	528	531

BIN CODE		λ_D (nm) at 20mA	
		Min.	Max.
BLUE	0D	465	468
	0C	468	471
	0B	471	474



American Opto Plus LED Corp.

L950L-LENPGQB

5.4 x 5.0 x 1.6 mm RBG SMD LED

TYPICAL ELECTRICAL-OPTICAL CHARACTERISTIC CURVES (RED)

Fig.1 Forward current vs. Forward Voltage

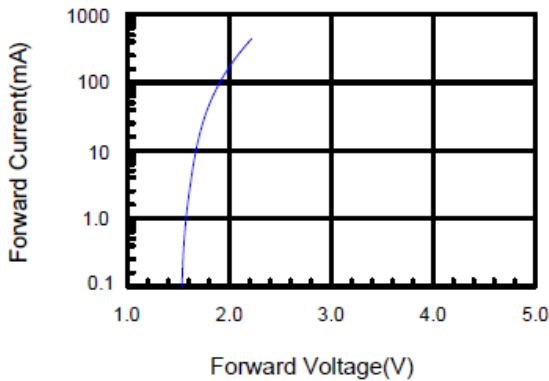

Fig.2 Relative Intensity vs. Forward Current

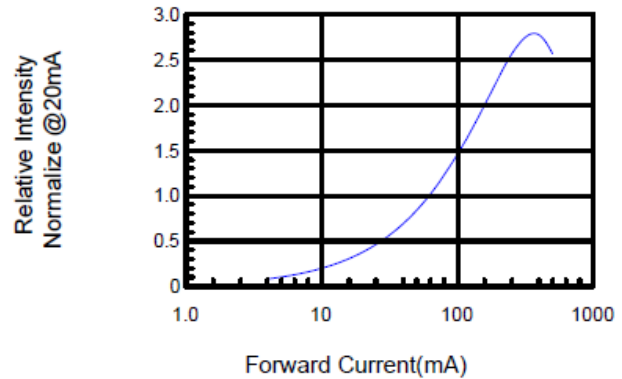

Fig.3 Forward Voltage vs. Temperature

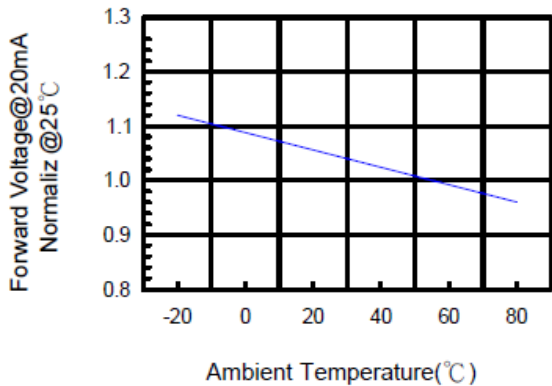

Fig.4 Relative Intensity vs. Temperature

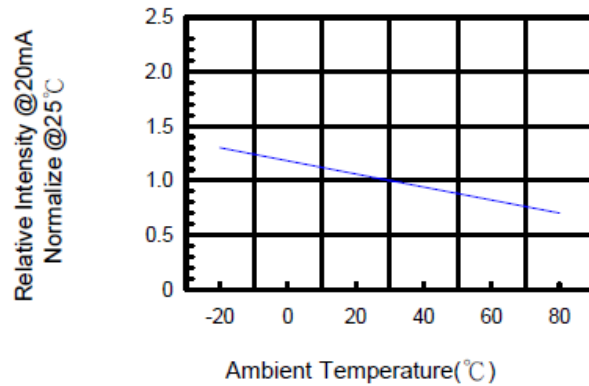

Fig.5 Relative Intensity vs. Wavelength

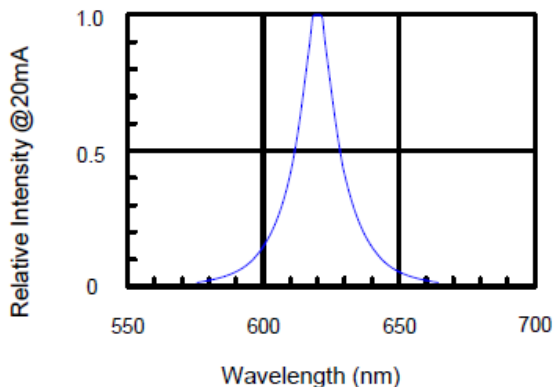
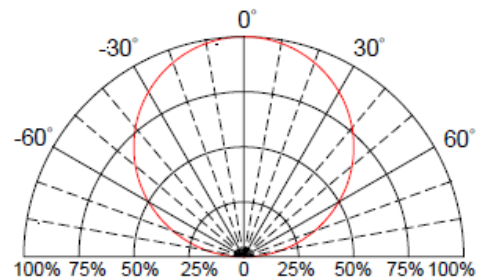

Fig.6 Directive Radiation





American Opto Plus LED Corp. L950L-LENPGQB

5.4 x 5.0 x 1.6 mm RGB SMD LED

TYPICAL ELECTRICAL-OPTICAL CHARACTERISTIC CURVES (GREEN)

Fig.1 Forward current vs. Forward Voltage

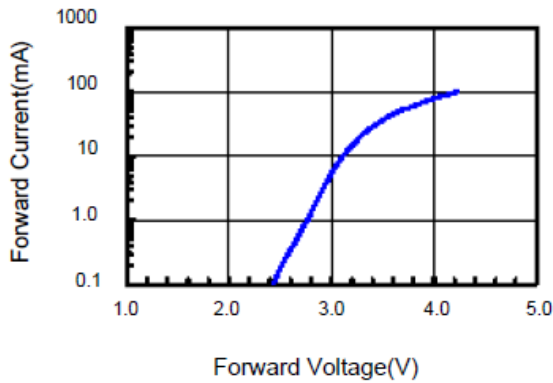

Fig.2 Relative Intensity vs. Forward Current

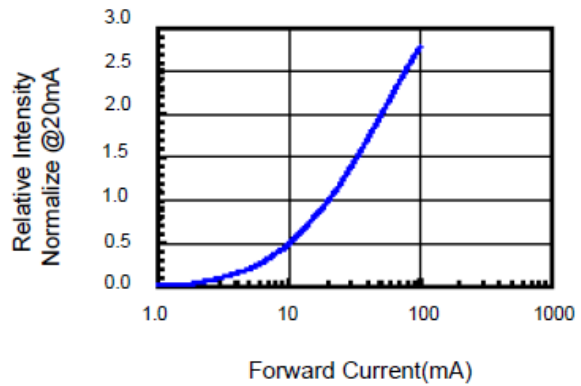

Fig.3 Forward Voltage vs. Temperature

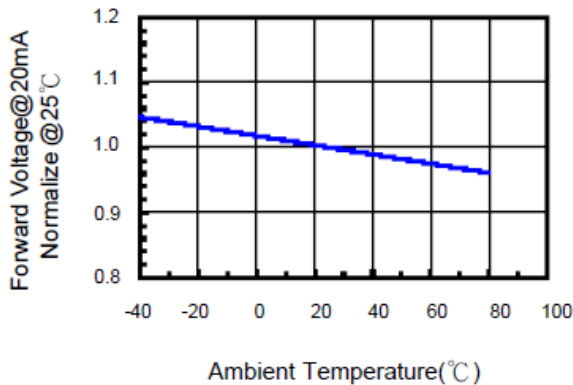

Fig.4 Relative Intensity vs. Temperature

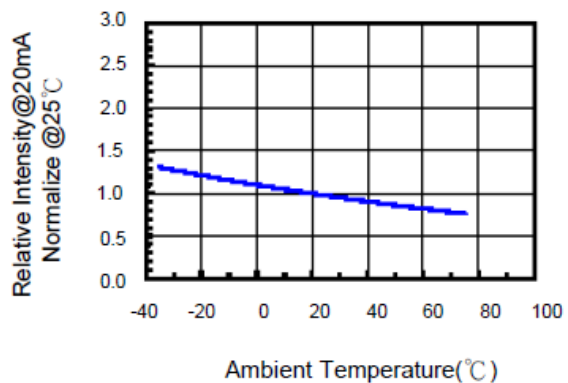

Fig.5 Relative Intensity vs. Wavelength

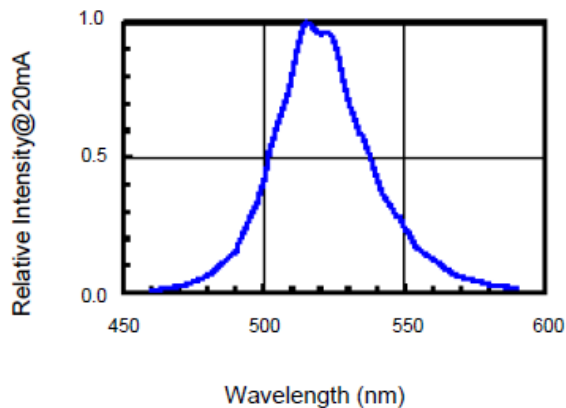
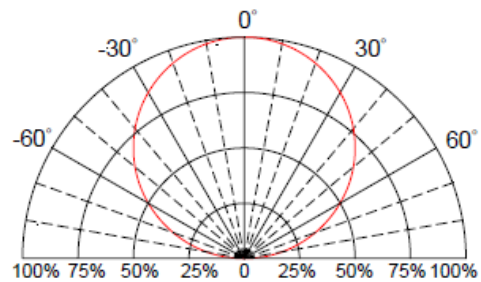

Fig.6 Directive Radiation





American Opto Plus LED Corp.

L950L-LENPGQB

5.4 x 5.0 x 1.6 mm RBG SMD LED

TYPICAL ELECTRICAL-OPTICAL CHARACTERISTIC CURVES (BLUE)

Fig.1 Forward current vs. Forward Voltage

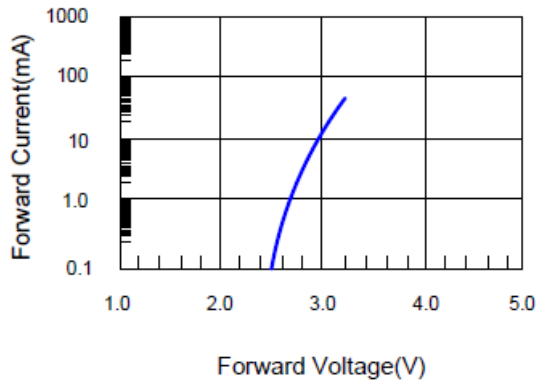

Fig.2 Relative Intensity vs. Forward Current

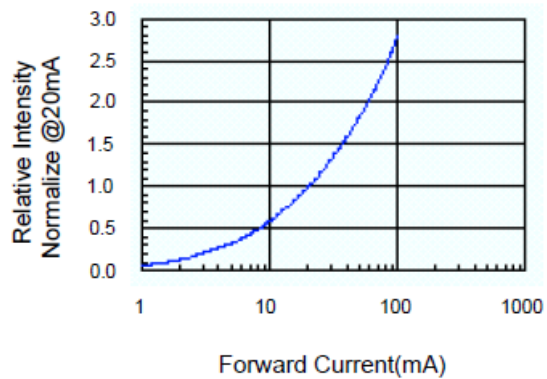

Fig.3 Forward Voltage vs. Temperature

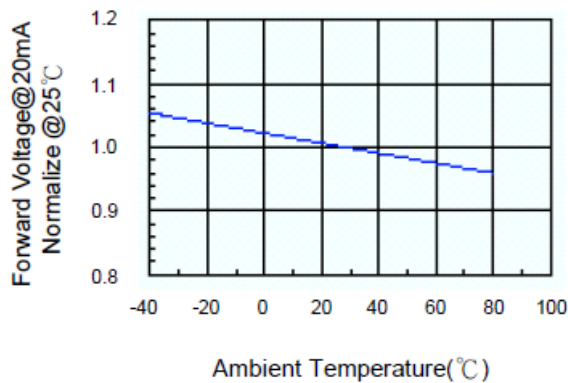

Fig.4 Relative Intensity vs. Temperature

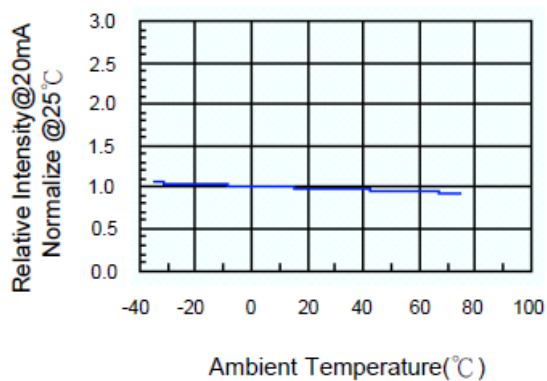

Fig.5 Relative Intensity vs. Wavelength

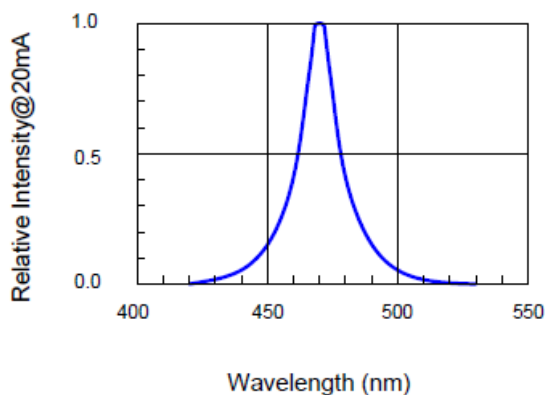
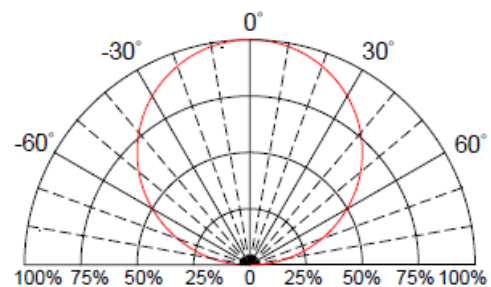

Fig.6 Directive Radiation





American Opto Plus LED Corp.

L950L-LENPGQB

5.4 x 5.0 x 1.6 mm RBG SMD LED

CARRIER TAPE DIMENSIONS

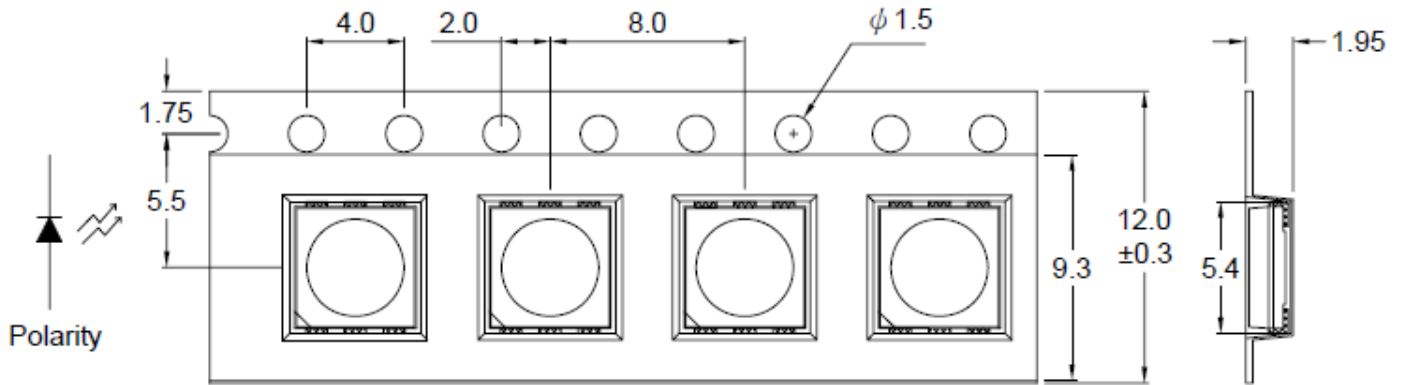

REEL DIMENSION

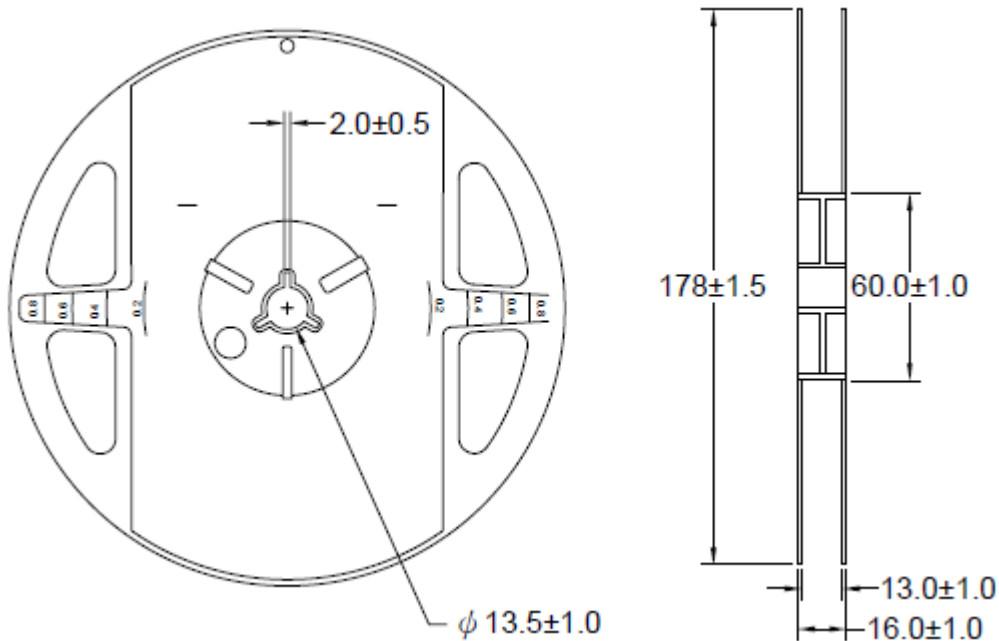

Notes:

1. 12.0mm tape, 7" Reel; 1,000 pcs/reel
2. Tolerance unless mentioned is ± 0.2 mm



American Opto Plus LED Corp.

L950L-LENPGQB

5.4 x 5.0 x 1.6 mm RBG SMD LED

SOLDERING CONDITIONS

Pb-Free solder temperature profile

Pb -free solder Temperature profile	
Pre-heat	180-200°C
Pre-heat time	120 Sec Max
Peak-Temperature	260°C Max
Soldering time condition	10 Sec Max

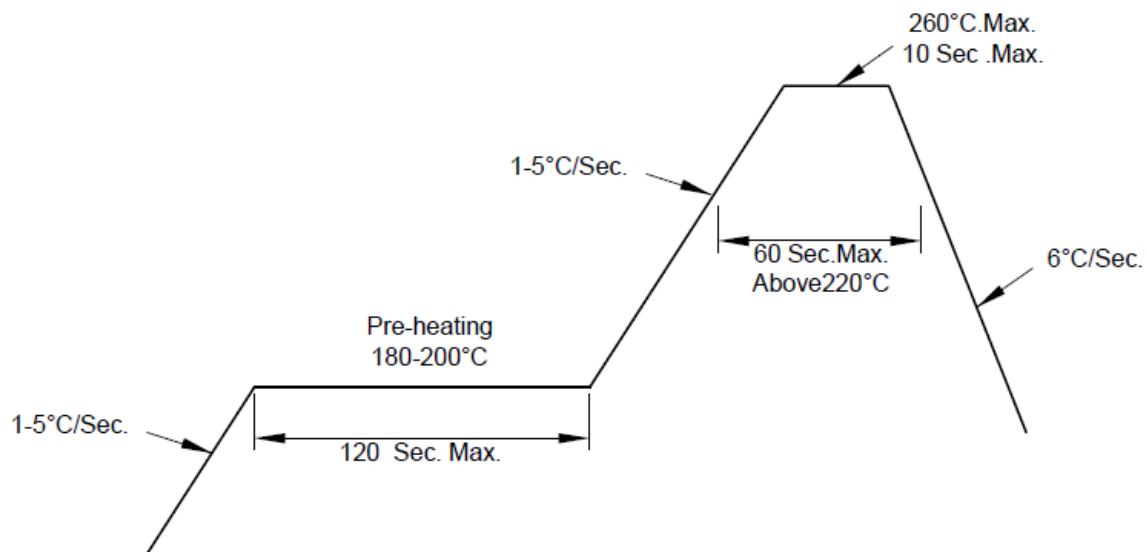

- Repairing should not be done after the LEDs have been soldered. When repairing is unavoidable, a double-head soldering iron should be used. It should be confirmed beforehand whether the Characteristics of the LEDs will or will not be damaged by repairing.
- Reflow soldering should not be done more than two times.
- When soldering, do not put stress on the LEDs during heating.
- After soldering, do not warp the circuit board.



American Opto Plus LED Corp.

L950L-LENPGQB

5.4 x 5.0 x 1.6 mm RBG SMD LED

RELIABILITY TEST

Classification	Test Item	Test Condition	Sample Size
Endurance Test	Operating Life Test	1.Ta=Under Room Temperature As Per Data Sheet Maximum Rating. 2.If=150mA 3.t=1000 hrs	22
	High Temperature Storage Test	1.Ta=105°C±5°C 2.t=500 hrs	22
	Low Temperature Storage Test	1.Ta=-40°C±5°C 2.t=1000 hrs	22
	High Temperature High Humidity Storage Test	1.IR-Reflow In-Board, 2 Times 2.Ta=85°C±5°C 3.RH=90%~95% 4.t=500hrs±2hrs	22
Environmental Test	Thermal Shock Test	1.IR-Reflow In-Board, 2 times 2.Ta=105°C±5°C & -40°C±5°C (30min) (30min) 3.total 100 cycles	22
	Reflow Soldering Test	1.T.Sol=260°C±5°C 2.Dwell Time= 10 Max.	22
	Temperature Cycling	1.105°C ~ 25°C ~ -40°C 30mins 15mins 30mins 2.100 Cyeles	22

(2)Criteria for judging the damage

Item	Symbol	Test Conditions	Criteria for Judgement	
			Min.	Max.
Forward Voltage	Vf	If=150mA	-	U.S.L x1.2
Reverse Current	Ir	Vr=5V	-	U.S.L x2.0
Luminous Intensity	Iv	If=150mA	L.S.L x 0.7	-