



American Opto Plus

PU-5WLWMX

High Power LED – Warm White

- ❖ High Flux Per LED
- ❖ Very Long Operating Life
- ❖ Lambertian or Collimated Radiation Pattern

Emitter Package: PU-5WLWME

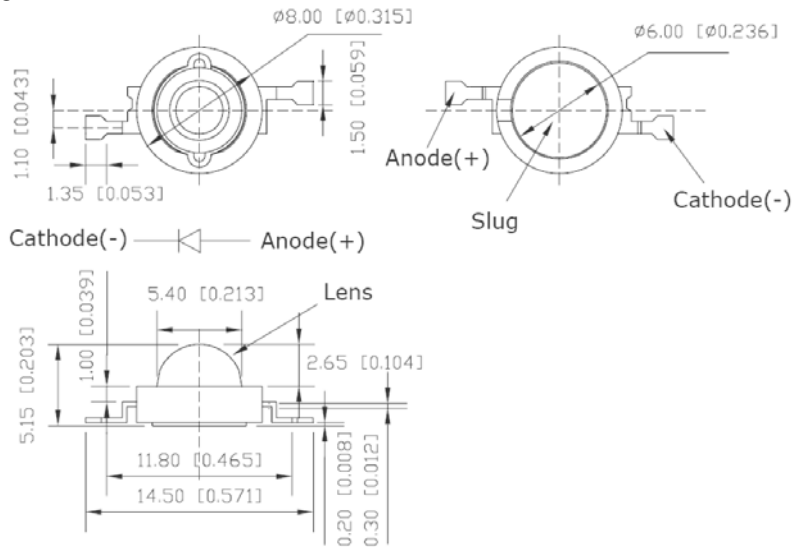

Star Package: PU-5WLWMS

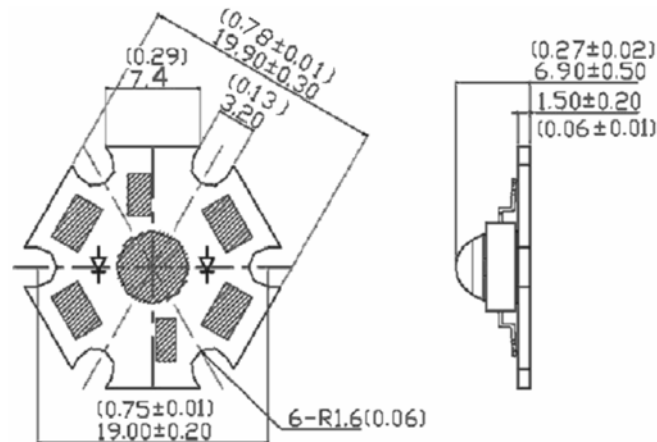

Notes:

1. Drawing not to scale
2. All dimensions are in millimeters
3. Tolerance is $\pm 0.25\text{mm}$ ($0.010''$) unless otherwise noted.
4. All dimensions without tolerances are for reference only.
5. Specifications are subject to change without notice.

SELECTION GUIDE

Emitting Color	Material	Lens Type	Luminous Flux $I_F=1000\text{mA}$ (lm)
Warm White	InGaN	Water Clear	210



American Opto Plus

PU-5WLWMX

High Power LED – Warm White

- ❖ High Flux Per LED
- ❖ Very Long Operating Life
- ❖ Lambertian or Collimated Radiation Pattern

ABSOLUTE MAXIMUM RATINGS

(Ta=25°C)

Parameter	Symbol	Max Rating	Unit
Forward Current	I _F	1000	mA
Peak Pulse Current (tp ≤ 100μs,Duty cycle = 0.25)	I _{pulse}	1500	mA
Reverse Voltage	V _R	5	V
LED Junction Temperature	T _J	125	°C
Operating Temperature Range	T _{OPR}	-40~+80	°C
Storage Temperature Range	T _{STG}	-40~+100	°C
Soldering Time at 260°C (Max)	T _{sol}	5	Seconds

Notes:

- 1.Proper current derating must be observed to maintain junction temperature below the minimum.
- 2.LEDs are not designed to be driven in reverse bias.

ELECTRICAL OPTICAL CHARACTERISTICS

(Ta=25°C)

Parameter	Symbol	Min	Typ	Max	Unit	Unit
Viewing Angle ^[1]	2θ1/2	-	135	-	Deg	I _F = 1000mA
Forward Voltage ^[2]	V _F	2.8	3.5	4.0	V	I _F = 1000mA
Reverse Current	I _R	-	-	10	μA	V _R = 5V
Color Temperature	CCT	2600	3000	4000	k	I _F = 1000mA
Luminous Flux	ΦV	160	210	-	lm	I _F = 1000mA

Notes:

1. 2θ1/2 is the off axis angle from lamp centerline where the luminous intensity is ½ of the peak value.
2. Forward Voltage measurement tolerance : ± 0.1V



American Opto Plus

PU-5WLWMX

High Power LED – Warm White

- ❖ High Flux Per LED
- ❖ Very Long Operating Life
- ❖ Lambertian or Collimated Radiation Pattern

Typical Electrical-Optical Characteristics Curves (25°C Ambient Temperature Unless Otherwise Noted)

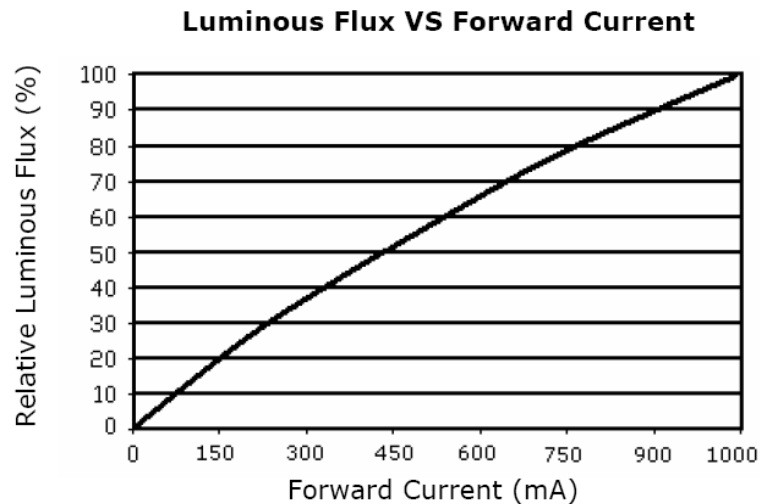
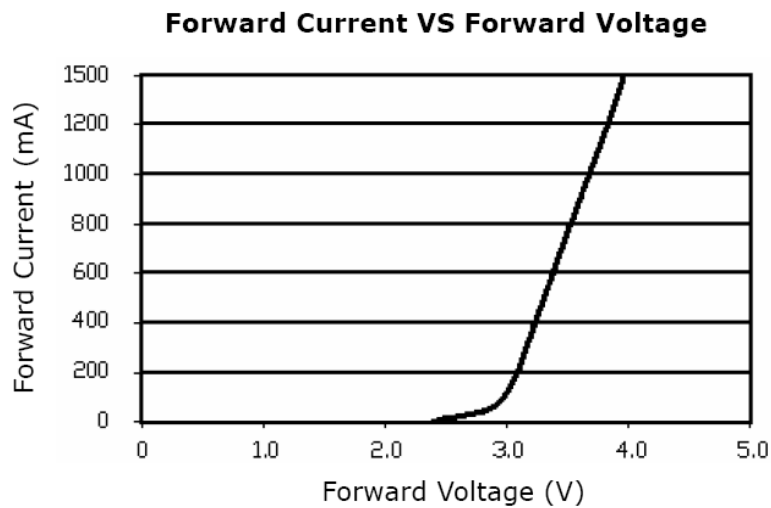
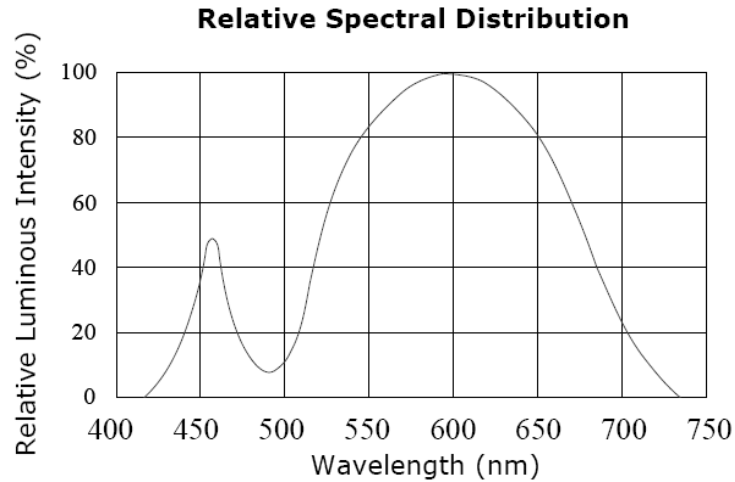



American Opto Plus

PU-5WLWMX

High Power LED – Warm White

- ❖ High Flux Per LED
- ❖ Very Long Operating Life
- ❖ Lambertian or Collimated Radiation Pattern

Typical Electrical-Optical Characteristics Curves

Maximum Current VS Ambient Temperature

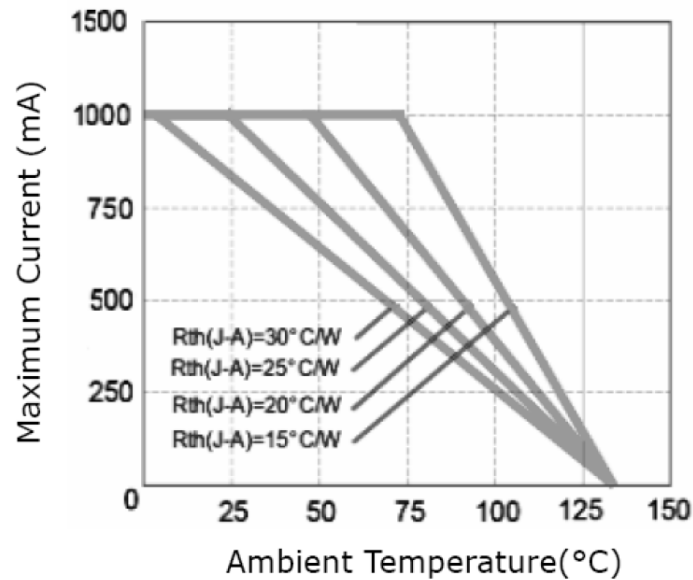

Typical Spatial Radiation Pattern

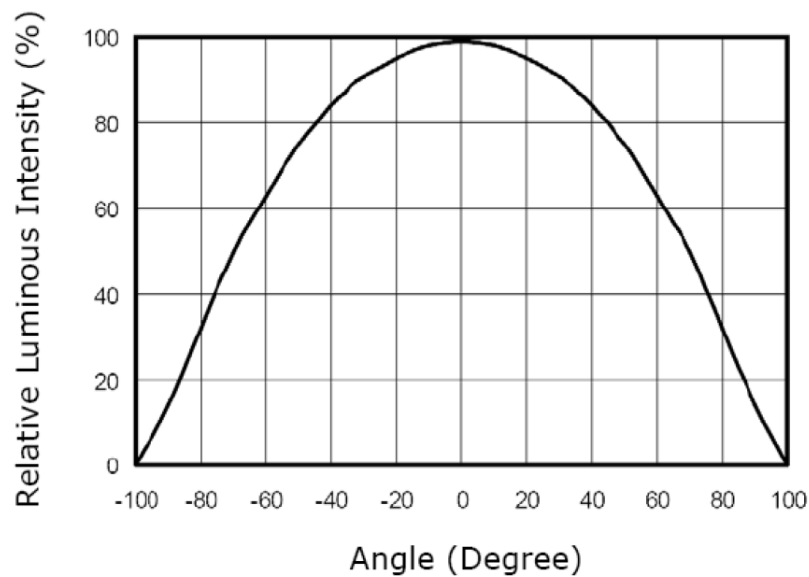



American Opto Plus
PU-5WLWMX
High Power LED – Warm White

- ❖ High Flux Per LED
- ❖ Very Long Operating Life
- ❖ Lambertian or Collimated Radiation Pattern

PRECAUTIONS FOR USE

1. Over-Current-Proof

Though this part has conducted ESD protection mechanism, customer must not use the device in reverse and should apply resistors for extra protection. Otherwise slight voltage shift may cause enormous current change and burn out failure would happen.

2. Storage

- Do not open moisture proof bag before the products are ready to use.
- Before opening the package, the LEDs should be kept at 30°C or less and 90% RH or less.
- The LEDs should be used within a year.
- After opening the package, the LEDs should be kept at 30°C or less and 70% RH or less.
- The LEDs should be used within 168 hours(7days) after opening the package.
- If the moisture absorbent material(silicone gel) has faded away or the LEDs have exceeded the storage time, baking treatment should be performed using the following conditions.
- Pre-curing treatment : 60±5°C for 24 hours

3. Thermal Management

- Because this part is a high power dissipation device, special and sufficient consideration in thermal management design must be made to optimize the thermal performance.
- Heat sink design is implemented in the device for an additional thermal connection. Since the device is capable for SMT process, tin must be spread both heat sink and solder pads areas to dissipate the heat.
- A high thermal conductivity substrate, such as Aluminum or copper plate ect, must be applied for external thermal management. It is strongly recommended that the outer heat sink or PCB dimensions per LED cannot be less than 25 x 25x 1 (L x W x H) mm. The materials for outer heat sink can be FR4 on Aluminum, MCPCB, or FPC on Aluminum.
- Special thermal design are also recommended to take in outer heat sink design, such as FR4 PCB on Aluminum with thermal vias or FPC on Aluminum with thermal conductivity, etc.
- Sufficient thermal management must be conducted, or the die junction temperature will be over the limit under large electronic driving and LED lifetime will decrease critically.

4. Soldering Condition

- Soldering should not be done more than two times.
- While soldering, do not put stress on the LEDs during heating.
- After soldering, do not warp the circuit board.

5. Soldering Iron

- For prototype building or small series production runs it is possible to place and solder the LED by hand.
- It is recommended to hand solder the leads with a solder tip temperature of 280°C for less than 3 seconds within once in less than the soldering iron capacity 25W. Leave two seconds and more intervals, and do soldering of each terminal.
- Be careful because the damage of the product is often started at the time of the hand solder.

6. Handling Indications

- During processing, mechanical stress on the surface should be minimized as much as possible. Sharp objects of all types should not be used to pierce the sealing compound.