



**American Opto Plus LED Corp.**  
**4.0" Case mold Type LED Display**  
**A4011LB-7 G/W**

● **EDIT HISTORY**

Version A: Dec. 19, 2012

Preliminary Spec.

Manufacture	Examination	Approving



# American Opto Plus LED Corp.

## 4.0" Case mold Type LED Display

### A4011LB-7 G/W

#### ● FEATURES

- 4.0 inch (101.6 mm) Digit Height.
- Excellent character appearance.
- Case mold type.
- Low Power Consumption.
- Gray face, White segment.
- RoHS compliant, Pb Free.

#### ● DESCRIPTION

The A4011LB-7 G/W is a 4.0 inch (101.6 mm) height single 7-segment display.. This device utilizes Super Bright Blue LED chip which are made from InGaN on a transparent GaN substrate. The display has Gray face, White segment.

#### ● DEVICE

PART NO	DESCRIPTION
Super Bright Blue	
A4011LB-7 G/W	Common Anode

**RoHS Compliance**



**Pb free.**





# American Opto Plus LED Corp.

## 4.0" Case mold Type LED Display

### A4011LB-7 G/W

#### ● MECHANICAL DIMENSIONS

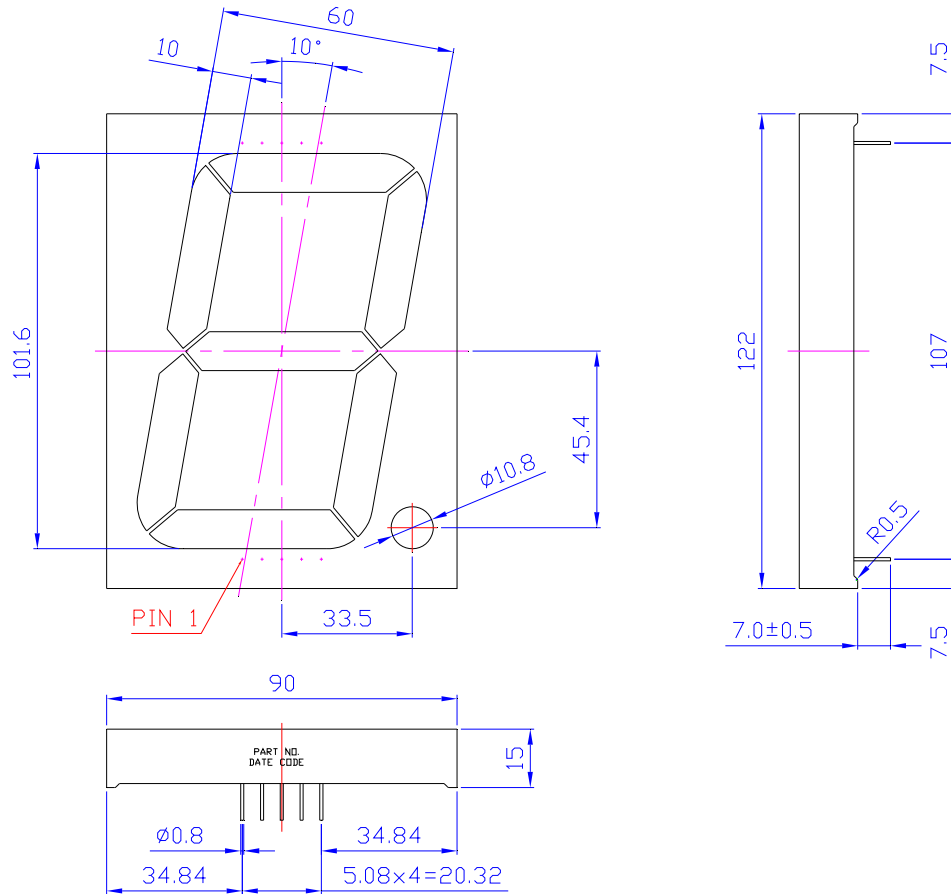

#### ● TYPICAL INTERNAL EQUIVALENT CIRCUIT

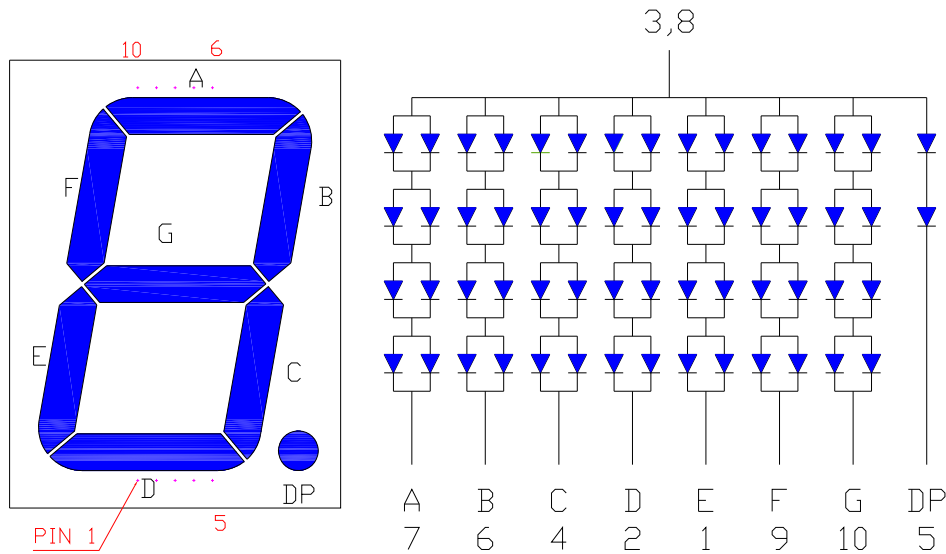



**American Opto Plus LED Corp.**  
**4.0" Case mold Type LED Display**  
**A4011LB-7 G/W**

● **LB: SUPER BRIGHT BLUE (InGaN/GaN)**

ABSOLUTE MAXIMUM RATING AT Ta=25°C

Parameter	Symbol	Super Bright Blue	Unit
Power dissipation per dice	P <sub>AD</sub>	120	mW
Derating liner from 25°C per dice	-	0.4	mA / °C
Continuous forward current per dice	I <sub>AF</sub>	30	mA
Peak current per dice (duty cycle 1/10, 1kHz)	I <sub>PF</sub>	100	mA
Reverse voltage per dice	V <sub>R</sub>	5	V
Operating temperature	T <sub>OPR</sub>	-25 to +85	°C
Storage temperature	T <sub>STG</sub>	-25 to +85	°C

ELECTRICAL - OPTICAL CHARACTERISTICS AT Ta=25°C

Characteristic	Symbol	Condition	Min.	Typ.	Max.	Unit
Forward voltage per Segment (DP)	V <sub>F</sub>	I <sub>F</sub> =20mA	-	12.0 (6.0)	14.4 (7.2)	V
Reverse current per Segment (DP)	I <sub>R</sub>	V <sub>R</sub> =40V (V <sub>R</sub> =16V)	-	-	10	µA
Dominant wavelength	λ <sub>D</sub>	I <sub>F</sub> =20mA	-	470	-	nm
Luminous intensity	I <sub>v</sub>	I <sub>F</sub> =10mA	-	200	-	mcd
Spectral radiation bandwidth	Δλ	I <sub>F</sub> =20mA	-	30	-	nm



# American Opto Plus LED Corp.

## 4.0" Case mold Type LED Display

### A4011LB-7 G/W

#### ● LB: SUPER BRIGHT BLUE (InGaN/GaN) CURVE

Typical Electro-optical Characteristic Curves  
(25 °C Free Air Temperature Unless Otherwise Specified)

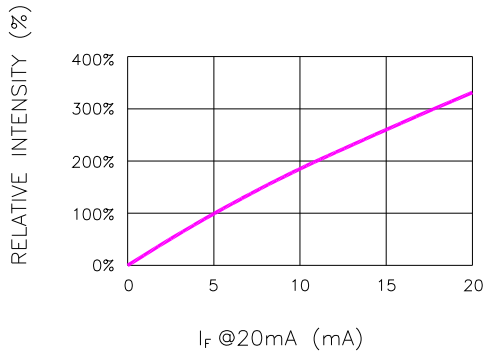

Fig.1 RELATIVE INTENSITY VS. FORWARD CURRENT

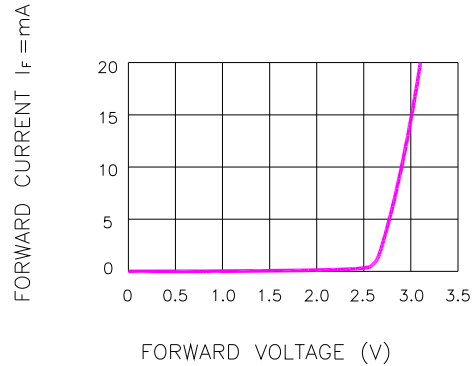

Fig.2 FORWARD CURRENT VS. FORWARD VOLTAGE

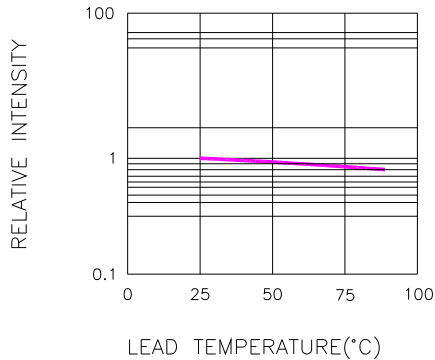

Fig.3 RELATIVE INTENSITY VS. LEAD TEMPERATURE  
(PULSED 20 mA; 300us PULSE, 10ms PERIOD)

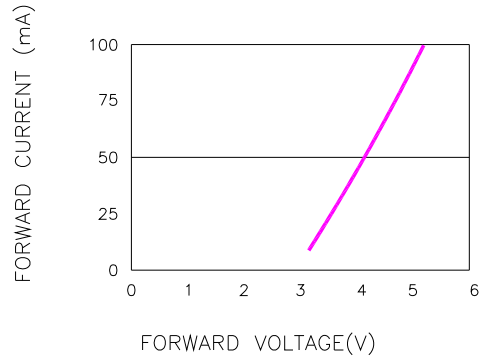

Fig.4 PEAK FORWARD VOLTAGE VS. FORWARD CURRENT  
(100us TEST PULSE, 1% DUTY CYCLE)

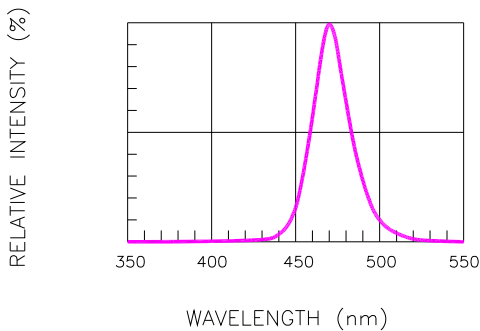

Fig.5 RELATIVE INTENSITY VS. WAVELENGTH

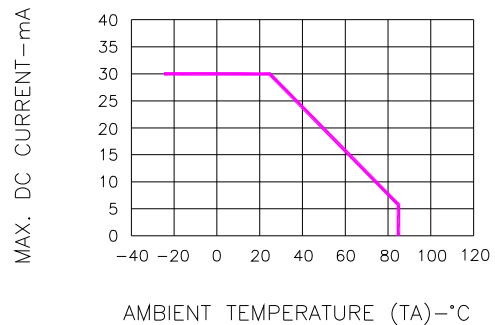

Fig.6 MAX. ALLOWABLE DC CURRENT VS. AMBIENT TEMPERATURE



# American Opto Plus LED Corp.

## 4.0" Case mold Type LED Display

### A4011LB-7 G/W

#### ● RECOMMEND SOLDERING PROFILE

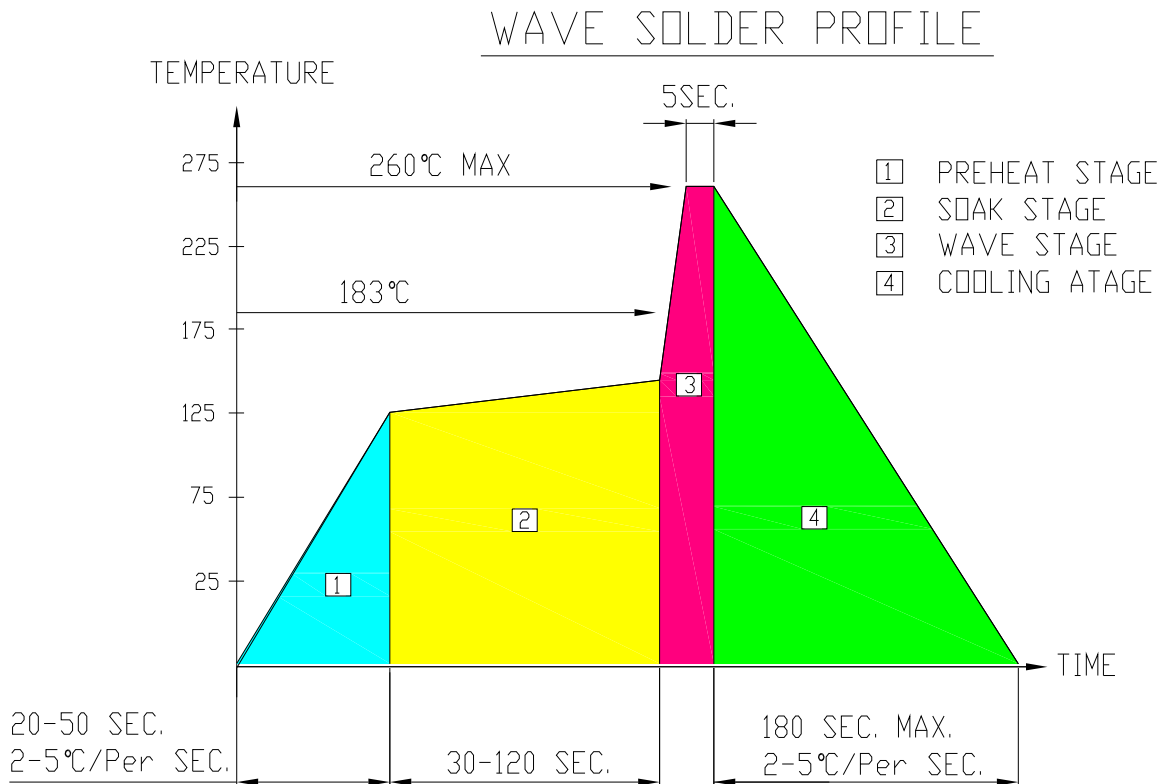

#### ● SOLDERING IRON

Basic spec is  $\leq 4$  sec when 260°C. If temperature is higher, time should be shorter (+10°C → 1 sec). Power dissipation of Iron should be smaller than 15W, and temperature should be controllable. Surface temperature of the device should be under 230°C.

#### ● REWORK

Customer must finish rework within  $\leq 4$  sec under 245°C.